

INSTALLATION

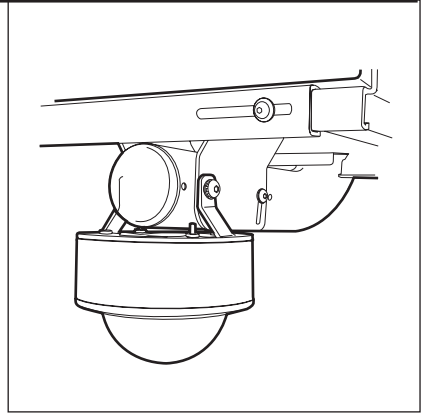

ICS-D0111ABK Integrated Camera System



MR5000 Series Public Viewing System

C2495M-A (1/06)

Important Safety Instructions

1. Read these instructions.
2. Keep these instructions.
3. Heed all warnings.
4. Follow all instructions.
5. Do not block any ventilation openings. Install in accordance with the manufacturer's instructions.
6. Do not install near any heat sources such as radiators, heat registers, stoves, or other apparatus (including amplifiers) that produce heat.
7. Only use attachments/accessories specified by the manufacturer.
8. Use only with the cart, stand, tripod, bracket, or table specified by the manufacturer, or sold with the apparatus. When a cart is used, use caution when moving the cart/apparatus combination to avoid injury from tip-over.
9. Refer all servicing to qualified service personnel. Servicing is required when the apparatus has been damaged in any way, such as power-supply cord or plug is damaged, liquid has been spilled or objects have fallen into the apparatus, the apparatus has been exposed to rain or moisture, does not operate normally, or has been dropped.
10. Installation should be done only by qualified personnel and conform to all local codes.
11. Unless the unit is specifically marked as a NEMA Type 3, 3R, 3S, 4, 4X, 6, or 6P enclosure, it is designed for indoor use only and it must not be installed where exposed to rain and moisture.
12. Use only installation methods and materials capable of supporting four times the maximum specified load.
13. Use stainless steel hardware to fasten the mount to outdoor surfaces.
14. To prevent damage from water leakage when installing a mount outdoors on a roof or wall, apply sealant around the bolt holes between the mount and mounting surface.
15. **CAUTION:** These servicing instructions are for use by qualified service personnel only. To reduce the risk of electric shock do not perform any servicing other than that contained in the operating instructions unless you are qualified to do so.
16. Only use replacement parts recommended by Pelco.

The product and/or manual may bear the following marks:



This symbol indicates that dangerous voltage constituting a risk of electric shock is present within this unit.



This symbol indicates that there are important operating and maintenance instructions in the literature accompanying this unit



Regulatory Notices

This device complies with Part 15 of the FCC Rules. Operation is subject to the following two conditions: (1) this device may not cause harmful interference, and (2) this device must accept any interference received, including interference that may cause undesired operation.

FCC, Class B (except auto iris models)

RADIO AND TELEVISION INTERFERENCE

This equipment has been tested and found to comply with the limits of a Class B digital device, pursuant to Part 15 of the FCC Rules. These limits are designed to provide reasonable protection against harmful interference in a residential installation. This equipment generates, uses, and can radiate radio frequency energy and, if not installed and used in accordance with the instructions, may cause harmful interference to radio communications. However there is no guarantee that the interference will not occur in a particular installation. If this equipment does cause harmful interference to radio or television reception, which can be determined by turning the equipment off and on, the user is encouraged to try to correct the interference by one or more of the following measures:

- Reorient or relocate the receiving antenna.
- Increase the separation between the equipment and the receiver.
- Connect the equipment into an outlet on a circuit different from that to which the receiver is connected.
- Consult the dealer or an experienced radio/TV technician for help.

You may also find helpful the following booklet, prepared by the FCC: "How to Identify and Resolve Radio-TV Interference Problems." This booklet is available from the U.S. Government Printing Office, Washington D.C. 20402.

Changes and modifications not expressly approved by the manufacturer or registrant of this equipment can void your authority to operate this equipment under Federal Communications Commission's rules.

This Class B digital apparatus complies with Canadian ICES-003.

Cet appareil numérique de la classe B est conforme à la norme NMB-003 du Canada.

Description

Designed specifically for the MR5000 Series public viewing system, the ICS-DO111ABK integrated camera system packages a camera and lens into a small, discreet, high-security dome.

Pelco's MR5000 Series public viewing system is specifically designed for retail applications to provide a clear, visual warning to potential shoplifters that these premises are under surveillance. When properly installed the station is an effective deterrent against shoplifting.

Installation

PREPARE VIDEO AND ELECTRICAL CABLING

1. Temporarily remove the bottom end cap of the MR5000 Series mount if the end cap is installed.
2. Feed the 42-inch video cable (provided) through the monitor feedthrough hole in the mount arm and out the bottom end of the mount arm.
3. Pull power wires through the ICS-DO111ABK feedthrough hole located at the bottom of the mount arm. Remove the 0.750-inch plug if it is installed.

INSTALL THE ICS-DO111ABK TO THE MR5000 MOUNT

Follow the steps below to install the ICS-DO111ABK to the MR5000 mount:

1. Align the adapter plate with the cover. Position the cover so that the notch on the side of the cover faces the back of the MR5000 mount.

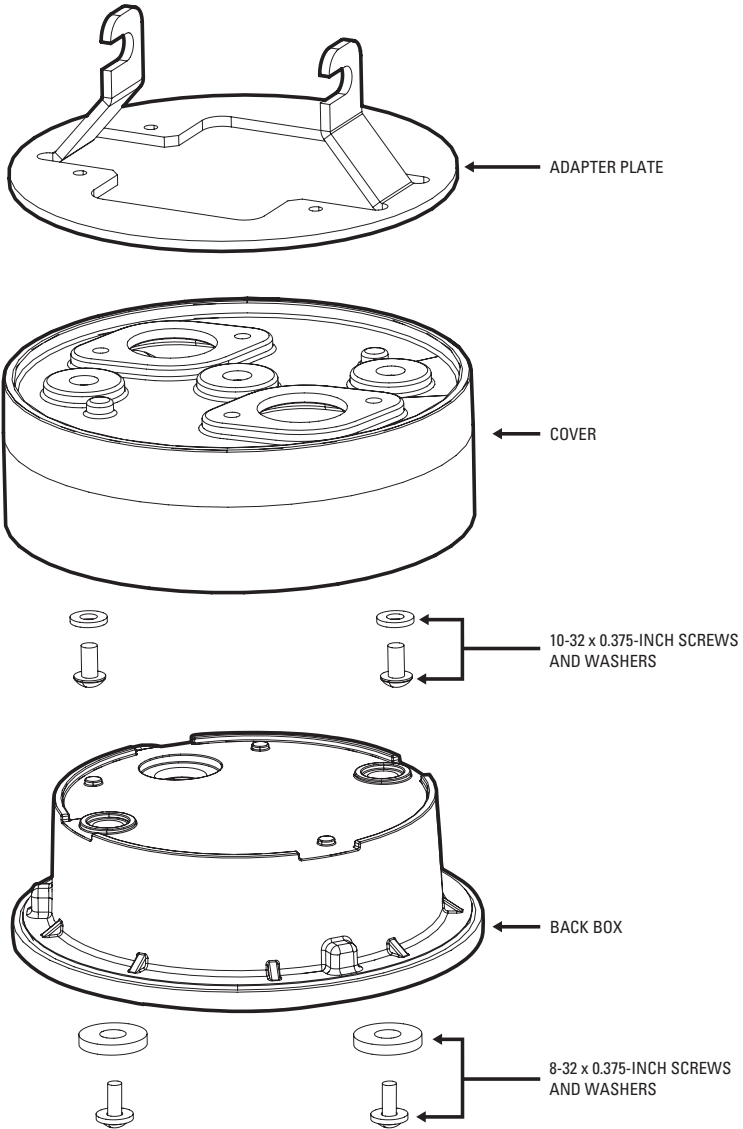

2. Using the two 10-32 x 0.375-inch pan head screws and internal lock washers, attach the cover of the ICS-DO111ABK to the adapter plate.

3. Do the following to install the back box inside the cover of the ICS-DO111ABK:
 - a. Feed the video cable and power wires attached to the ICS-DO111ABK back box through the cover and adapter plate of the ICS-DO111ABK.
 - b. Rotate and position the back box so that the conduit plug on the side of the box is located on the opposite side (180 degrees) from the notch on the side of the cover. Use the supplied 8-32 x 0.375-inch screws and washers to secure the back box to the cover.
4. Connect the power wires:
 - For 12 VDC, connect the 24 VAC/12 VDC (red) and GND (black) wires to input power. The blue wire is not used.
 - For 24 VAC, connect the 24 VAC/12 VDC (red) and 24 VAC (blue) wires to input power. The black wire is not used.
5. Feed the video connector from the Camclosure® base through the ICS-DO111ABK feedthrough hole in the mount and out the bottom of the mount arm. Connect the video connector to the mating connector of the video cable. Push the video cable back into the mount arm, and then reinstall the bottom end cap of the MR5000 Series mount.
6. Use the supplied 3/16-inch Allen wrench and slightly loosen (do not remove) the two 5/16-18 x 0.750-inch Allen pan head screws that secure the MR5000 mount base to the mount arm. Hook the adapter plate and cover over the loosened screws. Tighten the screws to secure the adapter plate to the mount.

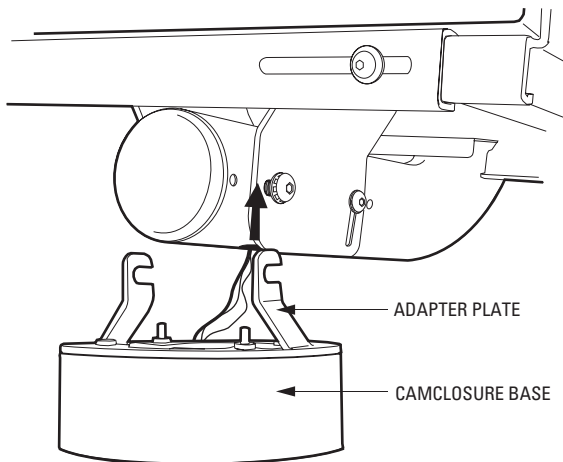

NOTE: POSITION THE BASE SO THAT THE CONDUIT OPENING IS TURNED TOWARD THE BACK OF THE MOUNT.

Install Camera

 **WARNING:** Heater elements could be hot! When camera power is on, use caution when adjusting the camera. This applies to all models.

1. Some indoor installations do not require a heater. If the installation does not require a heater, remove the heater board from the camera assembly. To remove the heater press on an end of the board.

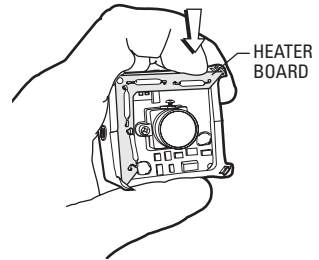

2. **12 VDC operation only:** The camera is set for 24 VAC operation at the factory. For 12 VDC operation remove the jumper from the 24 VAC position and install it in the 12 VDC position.

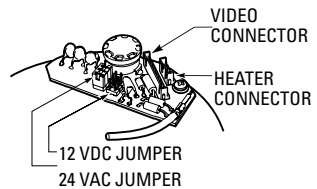

3. If the heater is installed, plug the heater connector from the camera into the mating connector inside the base. Plug the video connector from the camera into the mating connector inside the base.

Turn on power to the camera and monitor.

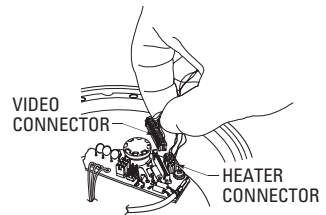

4. If you have a varifocal lens, hold the assembly in your hand and point the lens toward what you want to view. Loosen the focal length and focus locking screws. Adjust according to scene detail. Retighten the screws.

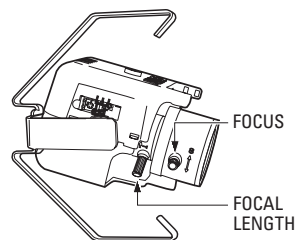

5. Always make sure the tab on the camera bracket is pointing out of the enclosure (away from the ceiling or wall). Gently squeeze the bracket, place it against the groove inside the back box, and gently release.

Proper camera orientation:

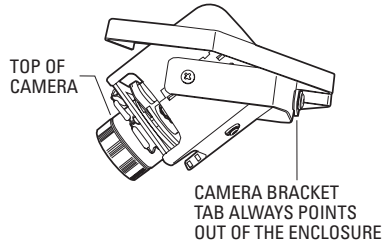
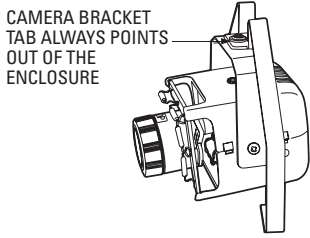

Install Dome and Trim Ring

1. Align the screw holes in the trim ring with those in the Camclosure base.
2. Domes with Liners (only) –
Position the viewing window over the lens of the camera by doing the following:

- a. Loosen the three Phillip screws located in the dome.
- b. Insert the blade of a standard screwdriver in one of the adjustment grooves. Move the dome into position.
- c. Tighten the three Phillip screws to lock the liner in place.

3. Tighten the tamper-resistant screws with the supplied 1/8-inch hollow screwdriver bit.

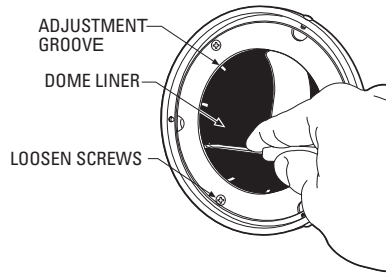

Adjustments (Color Camera Only)

If you have a color camera, it is set up at the factory and normally requires no adjustments. Sometimes, however, adjustments may be necessary.

1. Remove the dome and trim ring using the supplied 1/8-inch hollow screwdriver bit.
2. Adjust the vertical phase, iris level, focus, or switch settings (refer to procedures below).
3. Replace the dome and trim ring.

VERTICAL PHASE (24 VAC OPERATION ONLY)

Adjustment is required if there is vertical roll when switching between two cameras.

1. Reverse the 24 VAC connections on one camera. If both cameras are connected to the same transformer, this should solve the problem.
2. If reversing the connections does not solve the problem, or if cameras are connected to different transformers, turn the adjustment screw on one camera (while switching as rapidly as possible between the two camera views) until the switching is clean and there is no vertical roll. If more than two cameras are out of synchronization with each other, choose one camera and synchronize all others to it.

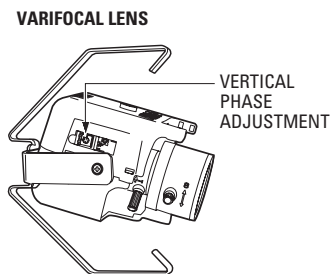
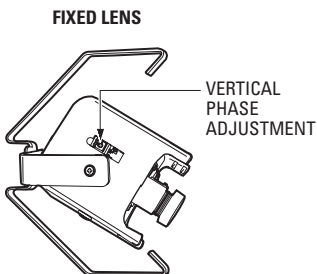

AUTO IRIS LEVEL ADJUSTMENT

If you have a varifocal lens or fixed focal length lens with an auto iris, you can adjust the level setting to increase or decrease brightness.

VARIFOCAL LENS

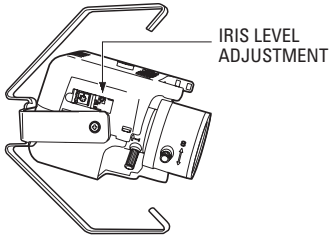

FIXED LENS

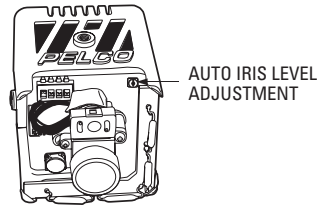

FOCUS ADJUSTMENT FOR FIXED FOCAL LENGTH LENS WITH AUTO IRIS



WARNING: Heater elements could be hot! When camera power is on, use caution when adjusting the camera.

To adjust the focus, it may be necessary to remove the heater board in order to loosen the locking screw on the bottom of the lens.

To remove the heater board:

1. Disconnect the four-pin heater wiring.
2. Wait for the heater elements to cool if they are hot.
3. Press on an end of the board.

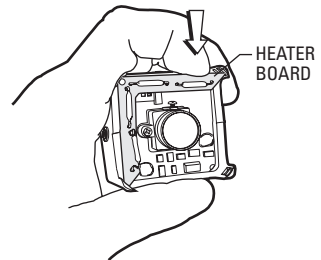

To adjust the focus:

1. Loosen the locking screw on the bottom of the lens.
2. Move the screw in the slot to bring the picture into focus.
3. Retighten the locking screw.
4. Replace the heater board if it was removed.
5. Reconnect the four-pin heater wiring.

FOCUS ADJUSTMENT SCREW

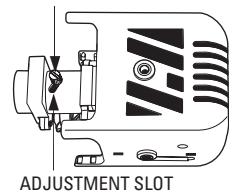

BOTTOM VIEW OF CAMERA
WITH HEATER BOARD REMOVED

SWITCH SETTINGS FOR FIXED FOCAL LENGTH LENS WITH AUTO IRIS

Refer to the switch drawing. The switch is located next to the lens. Automatic backlight compensation (factory setting) is used under varying lighting conditions (such as outdoors) or fixed lighting conditions where there are no bright spots that darken other picture details. Manual backlight compensation is used in fixed lighting conditions to optimize the picture detail when there are bright spots.

ALC/ELC switch:	Always ALC
Y/DC switch:	Always DC
Auto backlight compensation:	BLC switch OFF ABL switch ON
Manual backlight compensation:	BLC switch ON ABL switch OFF

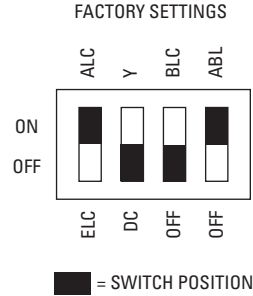

SWITCH SETTINGS FOR FIXED FOCAL LENGTH LENS WITHOUT AUTO IRIS

Refer to the switch drawing. The switch is located next to the lens. Automatic backlight compensation (factory setting) is used under varying lighting conditions (such as outdoors) or fixed lighting conditions where there are no bright spots that darken other picture details. Manual backlight compensation is used in fixed lighting conditions to optimize the picture detail when there are bright spots.

ALC/ELC switch:	Always ELC
Y/DC switch:	Not used
Auto backlight compensation:	BLC switch OFF ABL switch ON
Manual backlight compensation:	BLC switch ON ABL switch OFF

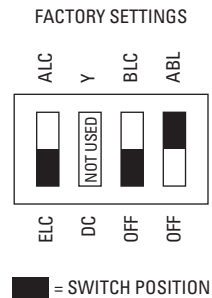

SWITCH SETTINGS FOR VARIFOCAL LENS

The high resolution camera with varifocal lens and auto iris is configured at the factory for automatic exposure.

AE Functions	1	AWB	Automatic white balance
	2	GAM	Gamma function
	3	AGC	Automatic gain control
	4	ESC	Electronic shutter control
	5	BLC	Backlight compensation
	6	FL	Flickerless
	7	AE	Automatic exposure
	8	Not used	

FACTORY SETTINGS							
1	2	3	4	5	6	7	8
■	■	■	□	□	■	■	■
□	□	□	■	■	□	□	□
OFF							
■ = SWITCH POSITION							

↑ ON

OFF ↓

For manually setting and locking the white balance, place a white background in front of camera and turn off switch 1.

For gamma correction, switch to accurately reproduce scene brightness; when turned on, $\gamma = 0.6$, and when turned off, $\gamma = 1.0$.

For automatic exposure, turn on switch 7, and then turn on/off switch 3 for AGC, switch 4 for electronic shutter control, switch 5 for backlight compensation, and switch 6 for flickerless motion.

For manual exposure and to enable auto iris, turn off switch 7; set switch 3 on to increase the gain by 6 dB or off to increase the gain by 18 dB; set switches 4, 5, and 6 for the desired shutter speed.

⚠ WARNING: Do not change the shutter speed unless you understand how changing the settings will affect the scene detail.

Shutter Speed	Switch Number and Position			
	7	6	5	4
1/60 (NTSC) 1/50 (PAL)	Off	On	On	On
1/100		Off	On	On
1/250		On	Off	On
1/500		Off	Off	On
1/1000		On	On	Off
1/2000		Off	On	Off
1/4000		On	Off	Off
1/10000		Off	Off	Off

Specifications

General

Operating Temperature	-50° to 122°F (-46° to 50°C) De-ices to 25°F (-4°C)
Cable Entry	3/4-inch (1.91 cm) conduit fitting and 3/4-inch (1.91 cm) opening for NPT threaded pipe
Pan/Tilt Adjustment	Manual; 360° pan; 180° tilt
Construction	Aluminum with steel camera mounting bracket and polycarbonate dome
Finish	Gray polyester powder coat
Environment	Low temperature, indoor/outdoor
Unit Weight	2.2 lb (1.0 kg)

Electrical

Input Voltage	12 VDC or 24 VAC, ±10%
Power Consumption	13 watts or less
Video Connector	BNC

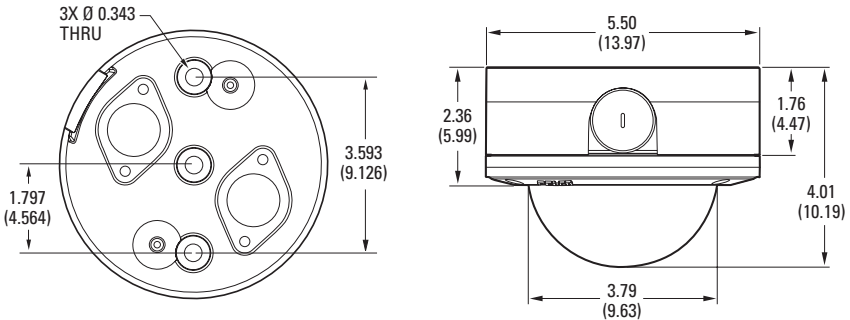

NOTE: VALUES IN PARENTHESES ARE CENTIMETERS;
ALL OTHERS ARE INCHES.

(Design and product specifications subject to change without notice.)



This equipment contains electrical or electronic components that must be recycled properly to comply with Directive 2002/96/EC of the European Union regarding the disposal of waste electrical and electronic equipment (WEEE). Contact your local dealer for procedures for recycling this equipment.

PRODUCT WARRANTY AND RETURN INFORMATION

WARRANTY

Pelco will repair or replace, without charge, any merchandise proved defective in material or workmanship **for a period of one year** after the date of shipment.

Exceptions to this warranty are as noted below:

- Five years on FT/FR8000 Series fiber optic products.
- Three years on Genex® Series products (multiplexers, server, and keyboard).
- Three years on Camclosure® and fixed camera models, except the CC3701H-2X, CC3751H-2, CC3651H-2X, MC3651H-2, and MC3651H-2X camera models, which have a five-year warranty.
- Two years on standard motorized or fixed focal length lenses.
- Two years on Legacy®, CM6700/CM6800/CM9700 Series matrix, and DF5/DF8 Series fixed dome products.
- Two years on Spectra®, Esprit®, ExSite™, and PS20 scanners, including when used in continuous motion applications.
- Two years on Esprit® and WWW5700 Series window wiper (excluding wiper blades).
- Two years (except lamp and color wheel) on Digital Light Processing (DLP®) displays. The lamp and color wheel will be covered for a period of 90 days. The air filter is not covered under warranty.
- Eighteen months on DX Series digital video recorders, NVR300 Series network video recorders, Endura™ Series distributed network-based video products, and TW3000 Series twisted pair transmission products.
- One year (except video heads) on video cassette recorders (VCRs). Video heads will be covered for a period of six months.
- Six months on all pan and tilts, scanners or preset lenses used in continuous motion applications (that is, preset scan, tour and auto scan modes).

Pelco will warrant all replacement parts and repairs for 90 days from the date of Pelco shipment. All goods requiring warranty repair shall be sent freight prepaid to Pelco, Clovis, California. Repairs made necessary by reason of misuse, alteration, normal wear, or accident are not covered under this warranty.

Pelco assumes no risk and shall be subject to no liability for damages or loss resulting from the specific use or application made of the Products. Pelco's liability for any claim, whether based on breach of contract, negligence, infringement of any rights of any party or product liability, relating to the Products shall not exceed the price paid by the Dealer to Pelco for such Products. In no event will Pelco be liable for any special, incidental or consequential damages (including loss of use, loss of profit and claims of third parties) however caused, whether by the negligence of Pelco or otherwise.

The above warranty provides the Dealer with specific legal rights. The Dealer may also have additional rights, which are subject to variation from state to state.

If a warranty repair is required, the Dealer must contact Pelco at (800) 289-9100 or (559) 292-1981 to obtain a Repair Authorization number (RA), and provide the following information:

1. Model and serial number
2. Date of shipment, P.O. number, Sales Order number, or Pelco invoice number
3. Details of the defect or problem

If there is a dispute regarding the warranty of a product which does not fall under the warranty conditions stated above, please include a written explanation with the product when returned.

Method of return shipment shall be the same or equal to the method by which the item was received by Pelco.

RETURNS

In order to expedite parts returned to the factory for repair or credit, please call the factory at (800) 289-9100 or (559) 292-1981 to obtain an authorization number (CA number if returned for credit, and RA number if returned for repair).

All merchandise returned for credit may be subject to a 20% restocking and refurbishing charge.

Goods returned for repair or credit should be clearly identified with the assigned CA or RA number and freight should be prepaid. Ship to the appropriate address below.

If you are located within the continental U.S., Alaska, Hawaii or Puerto Rico, send goods to:

Service Department
Pelco
3500 Pelco Way
Clovis, CA 93612-5699

If you are located outside the continental U.S., Alaska, Hawaii or Puerto Rico and are instructed to return goods to the USA, you may do one of the following:

If the goods are to be sent by a COURIER SERVICE, send the goods to:

Pelco
3500 Pelco Way
Clovis, CA 93612-5699 USA

If the goods are to be sent by a FREIGHT FORWARDER, send the goods to:

Pelco c/o Expeditors
473 Eccles Avenue
South San Francisco, CA 94080 USA
Phone: 650-737-1700
Fax: 650-737-0933

REVISION HISTORY

Manual #	Date	Comments
C2495M	10/05	Original version.
C2495M-A	1/06	Updated factory switch settings for varifocal lens. Updated wiring information.

Pelco, the Pelco logo, Camclosure, Esprit, Genex, Legacy, and Spectra are registered trademarks of Pelco.
Endura and ExSite are trademarks of Pelco.
DLP is a registered trademark of Texas Instruments, Inc.

©Copyright 2006, Pelco.
All rights reserved.



Worldwide Headquarters
3500 Pelco Way
Clovis, California 93612 USA

USA & Canada
Tel: 800/289-9100
Fax: 800/289-9150
International
Tel: 1-559/292-1981
Fax: 1-559/348-1120

www.pelco.com

ISO9001